

TECHNICAL DATA

RATED FLOW [M3/H]	15 m3/h
MAX FLOW	23m3/h
MAX HEAD	13.5M
OPTIMUM OPERATING RANGE @ 50HZ	9.0m3/hr @ 12.5m 65.4% eff 18.8m3/hr @ 7.3m 64.3% eff
WORKING AIR TEMP	0°C - 40°C
LIQUID TEMPERATURE	-15°C - 120°C
HIGHEST EFFICIENCY	68.5%
MAXIMUM PUMP PRESSURE	31 bar
NET WEIGHT (KG)	25 kg

RATED VOLTAGE/CURRENT	3~ 230V +10% - 6% 4.2A 3~ 415V +10% - 6% 2.31A
POWER (KW)	1.1kW 2 pole
MOTOR IP RATING	IP55
MOTOR INSULATION	Class F
MOTOR EFFICIENCY STD	I.E.3
MOTOR EFFICIENCY	82.7%
COS Ø	0.83
MECHANICAL SEAL	AS-L-16
OUTLET DIN FLANGE	DN50

DIMENSIONS

HEIGHT A	271
DIAMETER B	154
RADIUS C	124

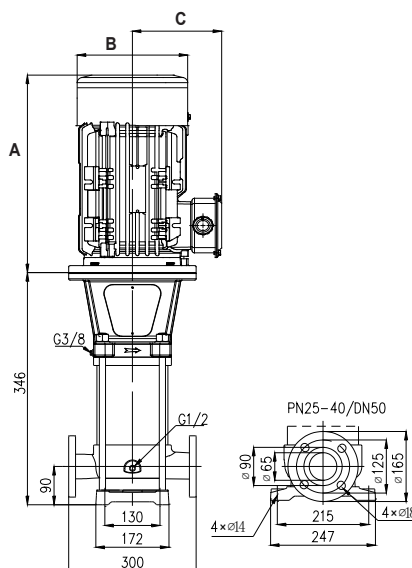

CURVE

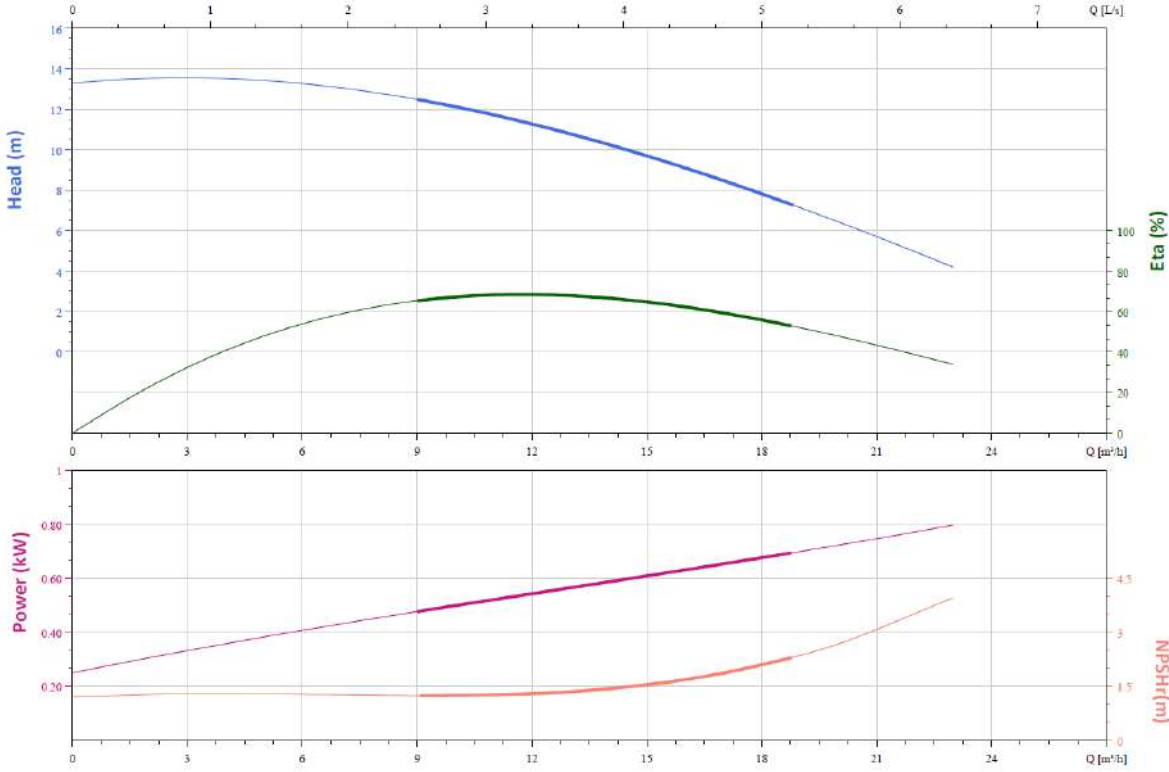

VFD CURVE

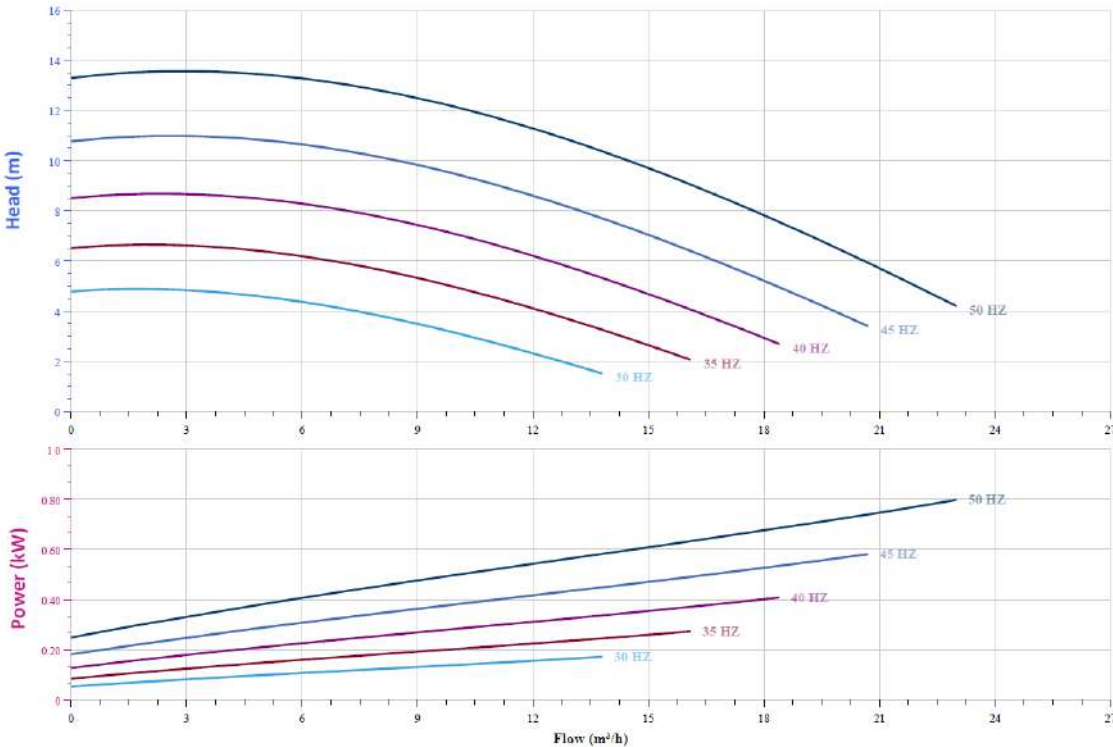

TWIN PUMP CURVE



CUTAWAY AND MATERIALS

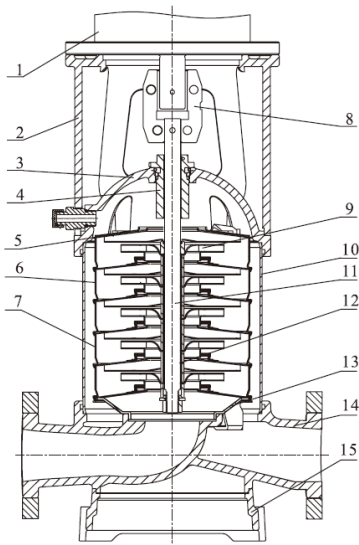

1	Motor	/
2	Bracket	Ductile Cast Iron
3	Seal Base	Stainless / Ductile Cast Iron
4	Mechanical Seal	AS-L-16
5	Top Diffuser	Stainless Steel
6	Diffuser	Stainless Steel
7	Support Diffuser	Stainless Steel
8	Coupling	Stainless Steel
9	Impeller	Stainless Steel
10	Cylinder	Stainless Steel
11	Shaft	Stainless Steel
12	Intermediate Bearing	SIC / WC
13	Inducer	Stainless Steel
14	Inlet/Outlet Chamber	Stainless Steel / Ductile Cast Iron
15	Base	Ductile Cast Iron

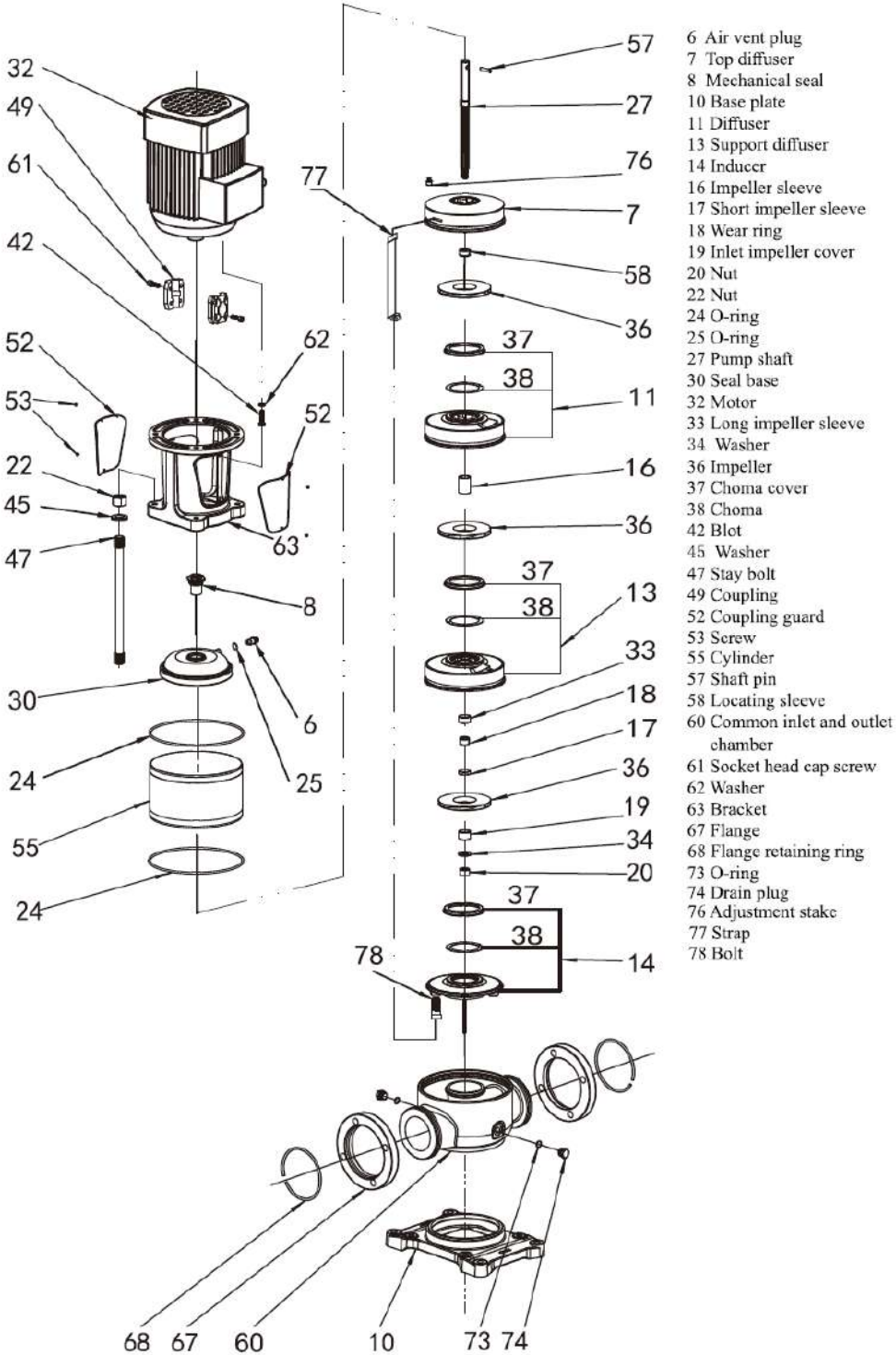

WARRANTY / CERTIFICATIONS

